

Features:

- Ultra-low capacitance (0.05pF typ.) ideal for high speed data, high frequency low voltage applications
- Provides ESD protection with fast response time (<1ns) allowing equipment to pass IEC 61000-4-2 level 4 test
- Single-line, bi-directional device for placement flexibility
- Low profile 0402/1005 design for board space savings
- Low leakage current (<0.1nA typ.) reduces power consumption

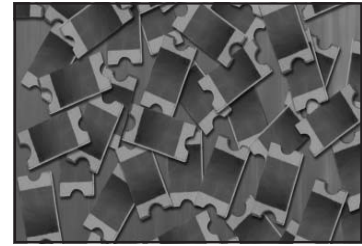

Description:

The PolySurg™ is specially designed to protect sensitive electronics from the threat of the electrostatic discharge (ESD). The product reacts almost instantaneously to the transient voltage and effectively clamps it to a low voltage for the duration of the ESD transient. The product uses voltage variable polymers based on SurgX® technology that inherently produce ultra low capacitance and very low leakage current. Thus the device is virtually invisible to the circuit during normal operational mode. It is especially transparent to the high-speed digital circuits due to the high off-state impedance and low capacitance.

Signals are not distorted or disrupted as shown by extensive testing. With PolySurg™ ESD protection, waveform definition stays true and high-speed signals do not degrade. The nature of the material creates a bi-directional part, which means that only one device per surge path is required to provide complete ESD protection regardless of the surge polarity. The low impedance surface mount package protects mobile communications, computers, data processing, test equipment, and many other electronic applications from ESD.

Product Dimensions: mm [inches]

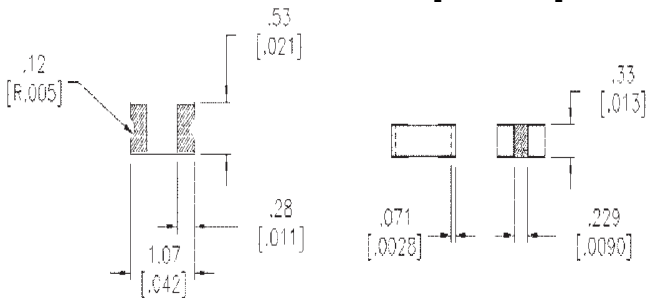

Solder Pad Recommendation: mm [inches]

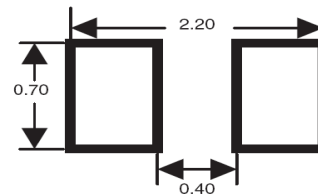

Environmental Specifications:

- Load Humidity: 12VDC per EIA/IS-772 Para. 4.4.2, +85°C, 85% RH for 1000 hours
- Thermal Shock: EIA/IS-722 Para 4.6, Air to Air -55°C to +125°C, 5 cycles
- Moisture Resistance Test: MIL-STD-202G Method 106G, 10 cycles
- Mechanical Shock: EIA/IS-722 Para. 4.9
- Vibration: EIA/IS-722 Para. 4.10
- Resistance to Solvent: EIA/IS-722 Para. 4.11
- Operating & Storage Temperature Range: -55°C to +125°C

Design Considerations

The location in the circuit for the SC7 series has to be carefully determined. For better performance, the device should be placed as close to the signal input as possible and ahead of any other component. Due to the high current associated with an ESD event, it is recommended to use a "0-stub" pad design (pad directly on the signal/data line and second pad directly on common ground).

For more information please contact our agent:

South China Enterprises (H.K) Ltd. Tel: 0852 2790 1991 Fax: 0852 2372 0008 E-mail : info@scehk.com

Part Ratings and Characteristics:

Performance Characteristics	Units	Min	Typ	Max
Continuous operating voltage	VDC	-	-	30 ¹
Clamping voltage ³	V	-	35	60
Trigger voltage ⁴	V	-	300	-
ESD Threat voltage capability ⁵	kV	-	8	15
Capacitance (@ 1 KHz ~ 1.8GHz)	pF	-	0.05	0.15
Leakage current (@ 12 VDC)	nA	0.01	<0.1	100
Peak current ³	A	-	30	45
Operating temperature	°C	-56	+25	+125
ESD pulse withstand ³	# pulses	20	>1000 ²	-
Attenuation Change (0 ~ 6GHZ)	dB		-0.2	

Notes:

1. The product is 100% tested for 30VDC operating voltage at 25°C. The product is also validated at long term, ambient temperature up to 30VDC.
2. Some shifting in characteristics may occur when tested over several hundred ESD pulses at very rapid rate of 1 pulse per second or faster.
3. Per IEC 61000-4-2, 30A @ 8kV, level 4, clamp measurement made 30ns after initiation of pulse, all tests in contact discharge mode.
4. Trigger measurement made using Transmission Line Pulse (TLP) method
5. All PolySurg™ devices are capable of withstanding up to a 15 kV, 45A ESD pulse. Device ratings are given at 8kV per Note 1, unless otherwise specified.

Applications

- | | | |
|--|---|--|
| <input type="checkbox"/> Computers & Peripherals | <input type="checkbox"/> P DA's | <input type="checkbox"/> High Speed Data Ports |
| <input type="checkbox"/> HDTV Equipment | <input type="checkbox"/> Digital Still Cameras | <input type="checkbox"/> USB 2.0 |
| <input type="checkbox"/> DVD Players | <input type="checkbox"/> Digital Camcorders | <input type="checkbox"/> IEEE 1394 |
| <input type="checkbox"/> A/V Equipment | <input type="checkbox"/> MP3 / Multimedia Players | <input type="checkbox"/> HDMI |
| <input type="checkbox"/> Satellite Radio | <input type="checkbox"/> Set Top Boxes | <input type="checkbox"/> DVI |
| <input type="checkbox"/> Cell Phones | <input type="checkbox"/> External Storage | <input type="checkbox"/> High Speed Ethernet |
| | <input type="checkbox"/> DSL Modems | <input type="checkbox"/> InfinibandR |

Temperature Ratings:

Normal Ambient Temperature:
23°C ± 3°C (74°F ± 3.6°F)
Operating Temperature:
-56°C to 125°C
Storage Temperature:
-56°C to 125°C

Soldering Methods:

Wave Solder: Reservoir Temperature: 260°C (500°F)
Time in reservoir: 10 seconds maximum
Infrared Reflow:
Temperature: 260°C
Time: 30 seconds maximum at peak temperature

Electrical Characteristics vs. Temperature

**Clamp Voltage & Trigger Voltage vs. Temperature
(Average & Minimum / Maximum)**

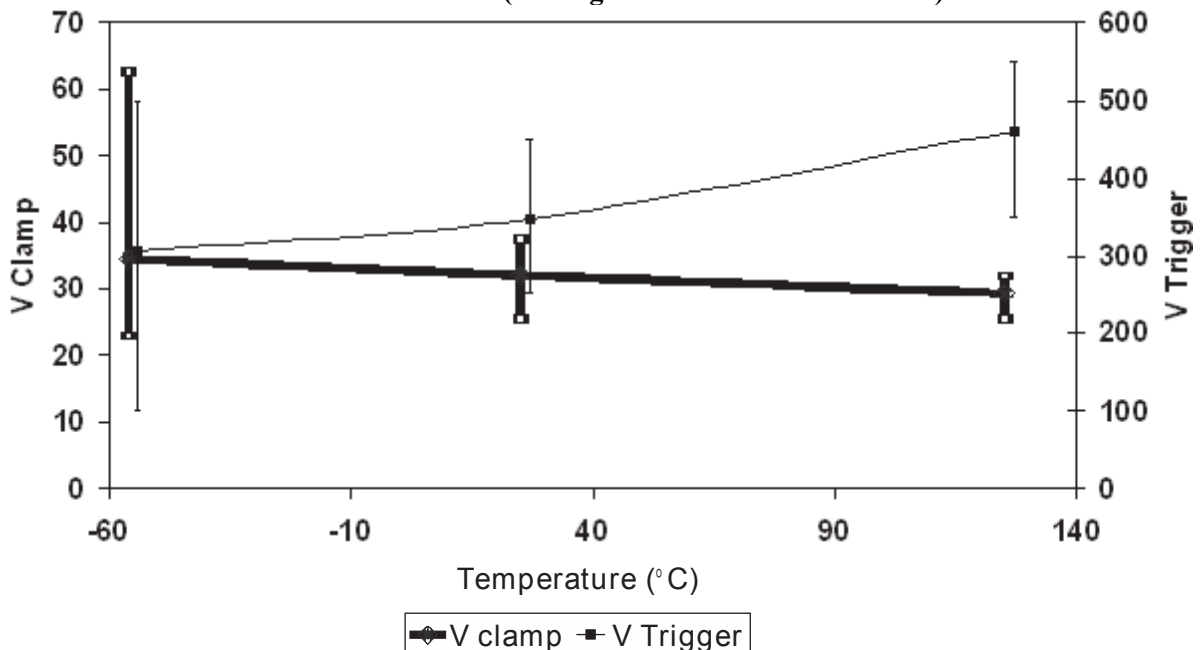

For more information please contact our agent:

South China Enterprises (H.K) Ltd. Tel: 0852 2790 1991 Fax: 0852 2372 0008 E-mail : info@scehk.com

Test Methodology

Full product characterization requires use of multiple test methods. Each test method reveals unique information about the device response. The results of all of the tests must be analyzed to fully understand the PolySurg™ device response to an over-voltage event.

Electrostatic Discharge (ESD) Pulse

The ESD pulse is the defining test for an ESD protective device. The ESD pulse is an extremely fast rising transient event. The pulse, as characterized in IEC 61000-4-2, has a rise time of less than 1ns, peak currents up to 45A, and voltage levels to 15 kV. Characteristics determined by this test are those such as voltage overshoot, peak voltage, clamping voltage, peak current, and device resistance.

Due to the extremely fast rate of rise of the ESD pulse, the test setup can have a definite impact on the above factors. Variables such as wiring inductance and probe capacitance can produce inaccurate readings on an otherwise capable oscilloscope.

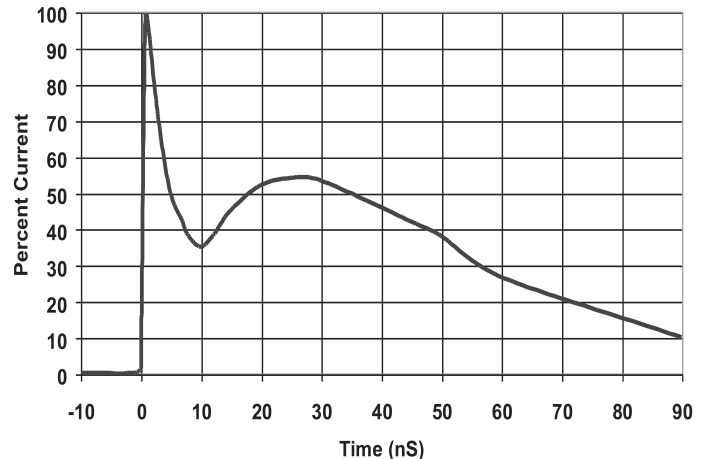

Transmission Line Pulse (TLP)

The Transmission Line Pulse tester implements a controlled impedance cable to deliver a square wave current pulse. The advantage of this technique is that the constant current of the square wave allows the behavior of the protection structure to be more accurately studied.

The actual implementation of this technique produces a waveform that has a slightly slower rise time than the ESD pulse but can be correlated to deliver approximately the same surge current and energy. This controlled impedance pulse provides a more accurate depiction of the trigger voltage of the device because of the reduced voltage overshoot caused by a fast rising transient and the reactive components of the test fixture.

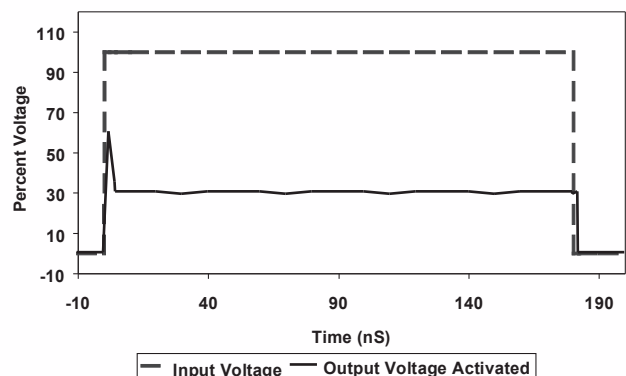

Definition of Terms

Clamp Voltage – The voltage at which the PolySurg™ device stabilizes during the transition from high to low impedance. This is the voltage experienced by the circuit, after stabilizing, for the duration of the ESD transient.

Trigger Voltage – The voltage at which the PolySurg™ device begins to function. When the ESD threat voltage reaches this level, the PolySurg™ device begins the transition from high impedance to low impedance, shunting the ESD energy to ground.

Threat Voltage – The voltage that the test equipment is set to operate (i.e. the voltage across the discharge capacitor).

Peak Current – The maximum instantaneous current level that a device will receive. IEC-61000-4-2 states that the peak current should be 30A at 8kV ESD and 45A at 15kV ESD.

For more information please contact our agent:

South China Enterprises (H.K) Ltd. Tel: 0852 2790 1991 Fax: 0852 2372 0008 E-mail : info@scehk.com

Selected Characterization Data

ESD Transient Pulse Energy Controlled by PolySurg™

Figure 1 shows typical PolySurg™ device response to an 8 kV contact ESD pulse. Triggered polymer in PolySurg™ conducts excess energy to ground and prevents system damage by ESD transient threat. As the polymer resistance drops current flows to ground.

The top scope trace indicates current, and the bottom scope trace indicates voltage.

Figure 1. Typical Device Response to 8kV ESD

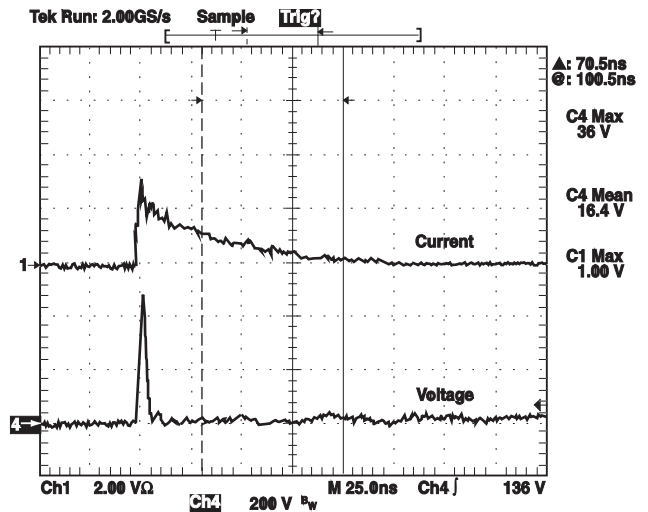

PolySurg™ Protects against ESD Voltage Transient without Affecting Signal Quality

The PolySurg™ ESD over voltage protection devices have an ultra low capacitance of <0.1pF and when typically installed from the signal line to ground PolySurg™ has a negligible effect on the signal.

As Figure 2 shows, the test conducted with a precision network analyzer on a 50 Ω circuit at up to 6GHz. Only a 0.2dB deviation from the original signal was recorded.

The setup was similar to the addition of the PolySurg™ device to a circuit with very fast digital signal or a cellular phone antenna.

Figure 2. SurgX® induced interference with Signal Quality

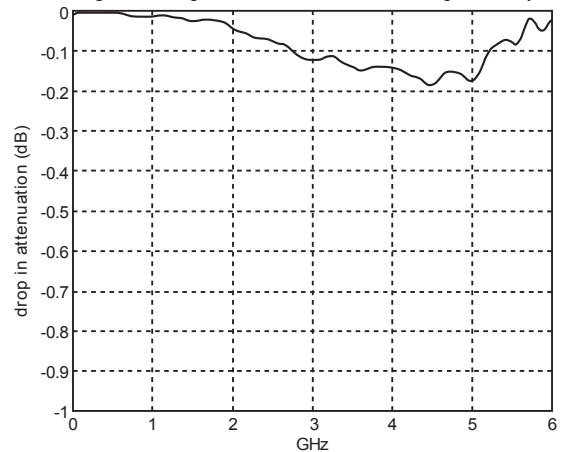

Signal Frequency does not affect the Capacitance of the Device

The device capacitance is very low and constant over wide frequency range. The typical capacitance is less than 0.15pF over the tested range of 0.1MHz to 1.8GHz. In addition, as shown in Figure 3, the capacitance will remain same over the life cycle of the device (i.e. the number of the ESD pulse does not change the device capacitance.)

Figure 3. Capacitance vs. Frequency

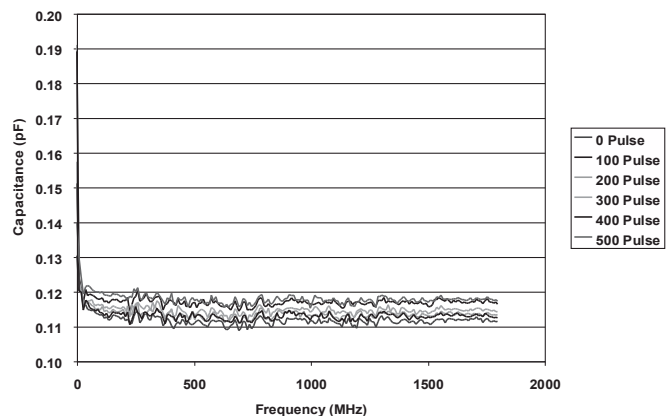

For more information please contact our agent:

South China Enterprises (H.K) Ltd. Tel: 0852 2790 1991 Fax: 0852 2372 0008 E-mail : info@scehk.com

Clamp Voltage Remains Consistent Despite Repeated ESD Pulses

As Figure 4 shows, the PolySurg™ device is highly reliable and stable over hundreds of pulses.

The PolySurg™ device has been tested with fast rate ESD pulses at 8kV contact discharge. Clamping voltage measured at every pulse shows minimal changes throughout the test.

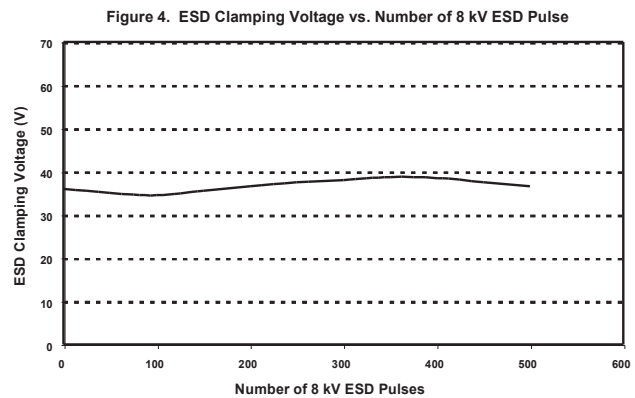

Typical non-triggered (Off State) Current Leakage of PolySurg™ is Very Low at Normal Operating Voltages and Temperatures

As shown by Figure 5 the current leakage of PolySurg™ is typically very low, well under 1nA, even over 12VDC operating voltage. Some increase in the current leakage may be expected at much higher operating voltage and elevated temperature.

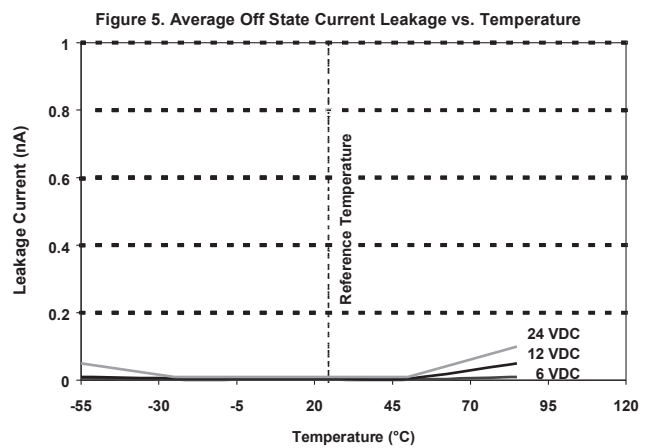

Ordering Information

0402 ESD A SC 7
1 2 3 4 5

1. Package Size
2. Product Family
3. Device Characteristics (A=Standard)
4. Customer Code
5. Packaging Code

Soldering Recommendations

- Compatible with lead and lead-free solder reflow processes
- Peak reflow temperatures and durations:
- IR Reflow = 260°C max for 10 sec. max.
- Wave Solder = 260°C max. for 10 sec. max.
- Recommended IR Reflow Profile:

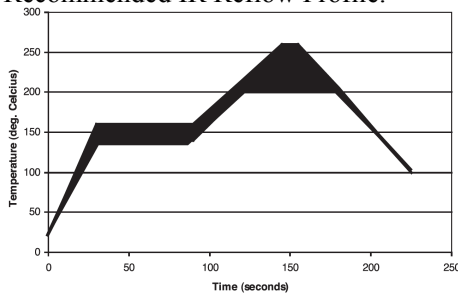

Packaging Code

- 10,000 pieces in paper tape on 7 inch (178mm) plastic reel per EIA Standard 481-1

Tape & Reel Specifications

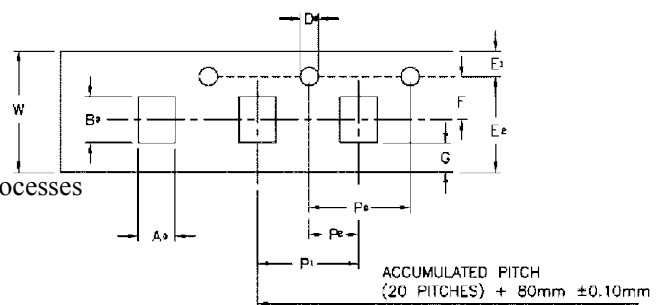

Nominal Carrier Dimensions (mm)										
A ₀	B ₀	D ₀	E ₁	E ₂	F	G	P ₀	P ₁	P ₂	W
0.78	1.35	1.50	1.75	6.25	3.50	2.75	4.00	2.00	2.00	8.00

For more information please contact our agent:

South China Enterprises (H.K) Ltd. Tel: 0852 2790 1991 Fax: 0852 2372 0008 E-mail : info@scehk.com